

# E-fusion

## Installation instruction



## Installation instructions for Krah pipes with an integrated electro fusion socket

1.

**Electric power supply:** Generator with minimum capacity of 15 kVA. Pay attention to a constant power output or electricity connection with 3 phases and 400v. (Pic.1)



picture 1

2.

Welding is just to be done by authorized personnel. (Pic.2)



picture 2

3.

The welding area has to be protected against dirt, humidity, and direct solar radiation. In case of temperatures below +5°C appropriate actions like covering by a tent and preheating are to be carried out to prevent a further decrease of temperature. (Pic. 3)



picture 3



picture 4

4.

Do not remove the protective film before cleaning and assembling of the socket and spigot end. ( Pic.4)

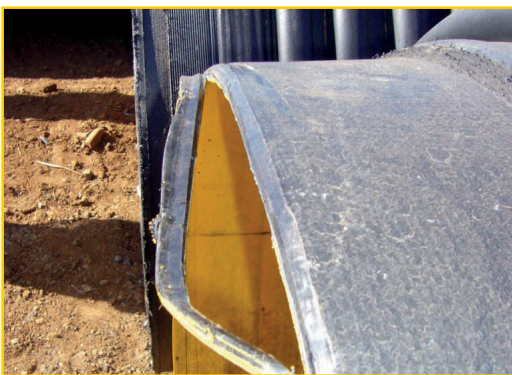

picture 5

5.

Check socket and spigot end for transportation damages. (Pic. 5)



picture 6

6.

Position the pipes so that the welding connections are easily accessible. (Pic.6)



picture 7

7.

Socket and spigot end have to be cleaned with PE cleaner, lint-free and a non - pigmented paper towel. (Pic.7)

8.

Mark insert-depth (according to the socket length) at the spigot end with a waterproof pen. (Pic. 8)



picture 8

9.

Insert the KRAH chain tensioning device into the groove at the socket end, the KRAH chain tensioning device has to be placed staggered to the connection wires (distance at least 45°). (Pic. 9)



picture 9

10.



Place a support ring into the spigot end (only necessary from a diameter of DN/ID800). The positioning of the support ring (approx. 20 mm from edge) as well as its tensioning has to be done **AFTER** putting the Krah pipes together. (Pic.10)

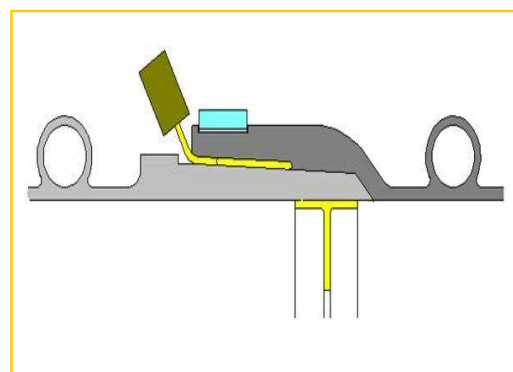

picture 10

11.

Put the pipes together until arrester / marking; adjust them axially and vertically. Take care that there is no humidity between socket and spigot end. (Pic.11)



picture 11

**All these preparations have to be done before welding!**



picture 12

12.

Tighten the chain with the chain tensioning device according to the table at the operating instruction for tensioning tool with chain. (Pic.12)

Check whether it is no encircling gap between the socket and spigot end is seen. Given case, the torque can be increased slightly until the gap is closed.



picture 13

13.

In case of short-length pipes fix socket and spigot end additionally. (Pic.13)



picture 14

14.

Connect the adapter with the connection wire. Now join the welding wires of welding device and the connection adapter (Pic. 6). Take care that no tractive forces interfere with the connection wires (danger of short-circuit). (Pic.14)



picture 15

15.

Enter welding parameter into welding device (Barcode or manually). Start the welding process. (Pic. 15)

16.

During the last third of the welding time retighten the KRAH chain tensioning device. (Pic.16)



picture 16

17.

After the welding procedure, mark the seam with a waterproof pen (seam number, date, welding voltage and time, welder). Remove the adapter from the connection wires. (Pic.17)



picture 17

18.

Do not move the pipe during cooling time. (Pic.18)



picture 18

19.

After the cooling process (approx. 45 min) remove tightening tool chain and support ring (inside). (Pic.19)

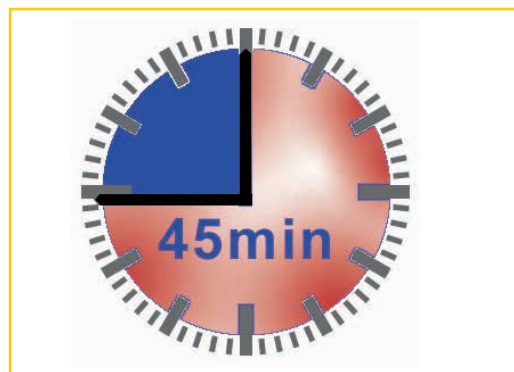

picture 19

20.

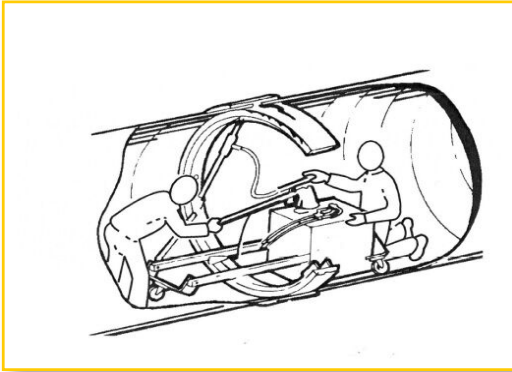

picture 20

The tightness of the welding connection has to be checked according to DIN EN 1610 (from DN 300 e.g. with a pneumatic socket test device).

It is very important to test the tightness (according to DIN EN 1610, section 10) before filling the sides respectively before inserting into a jacket tube. (Pic. 20)

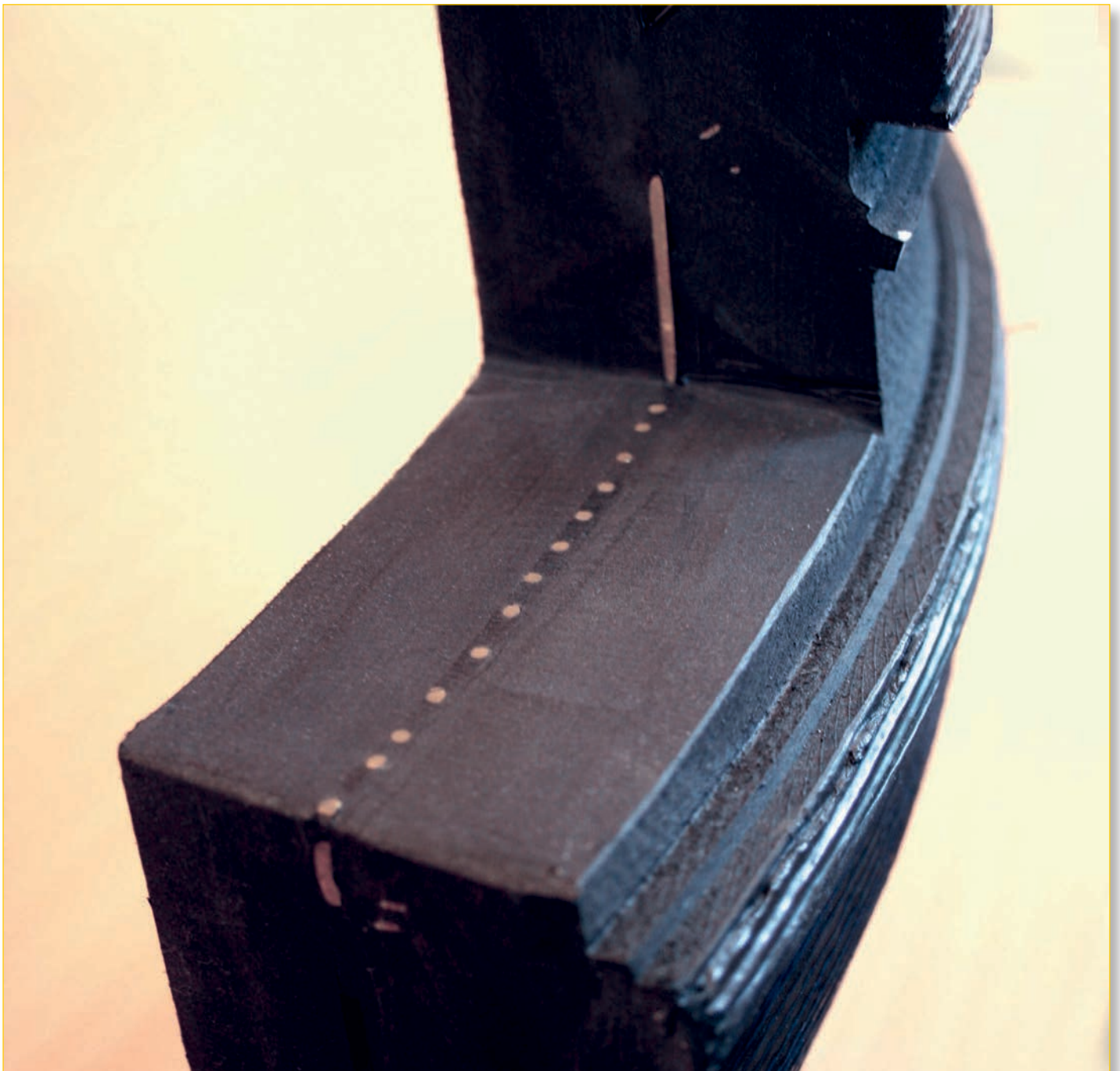

Get more information from your local Krah Pipe producer:

